

A B C D E F

1

2

3

4

5

2017.12.22\_REV.09

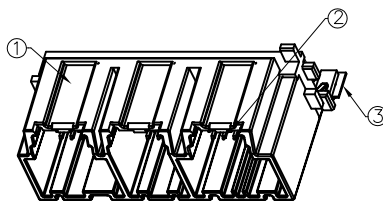
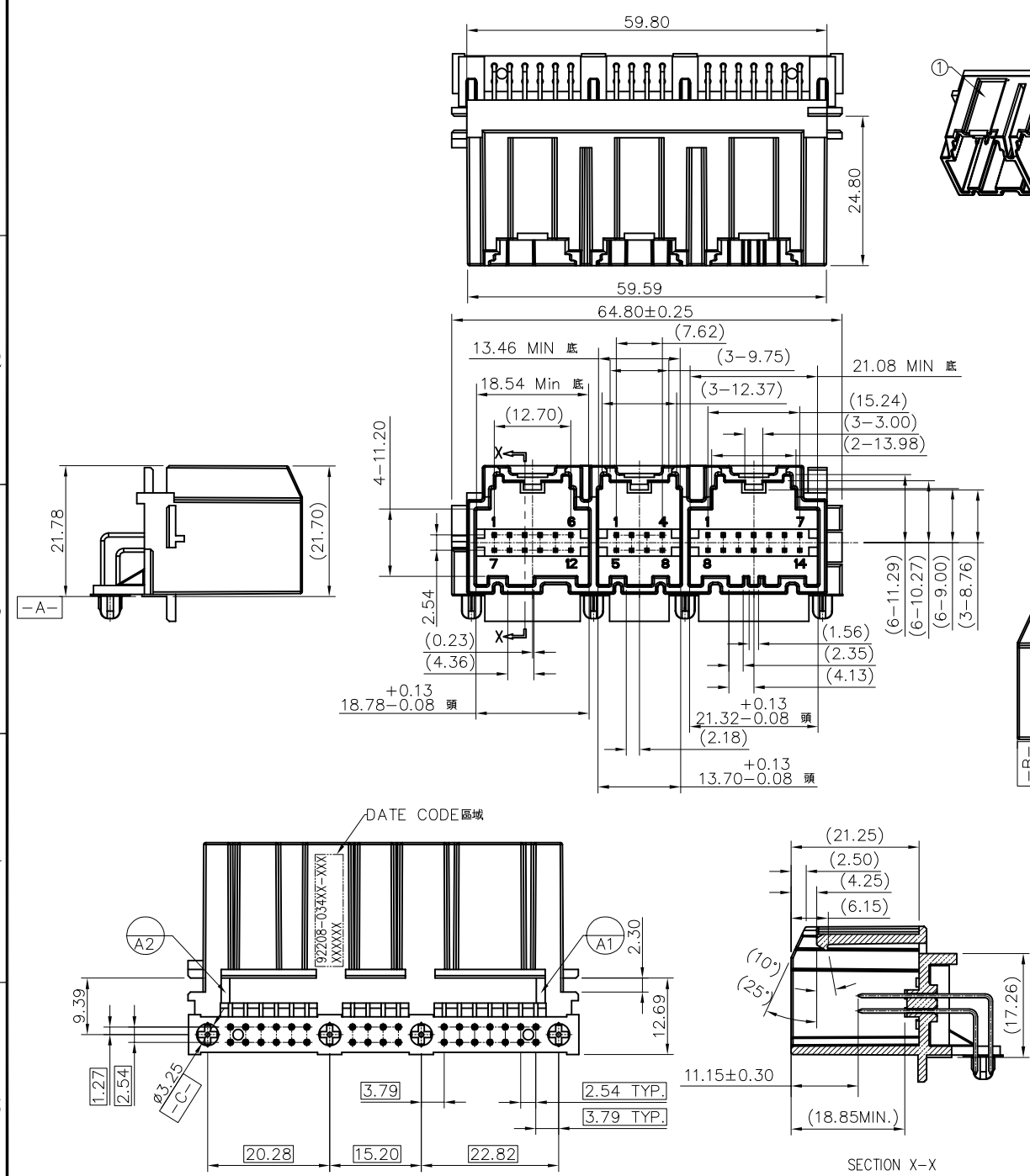



NOTES:  
 1. MATERIAL:  
 1.1 HOUSING: THERMOPLASTIC, HIGH TEMP., UL94 HB; COLOR: BLACK  
 1.2 CONTACT: BRASS  
 1.3 SUTTER: PET, T=0.25mm, COLOR: NATURAL  
 2. FINISH:  
 2.1 CONTACT:  
 TIN PLATING OVERALL  
 NICKEL UNDERPLATING OVERALL.  
 3. CUSTOMER PART NUMBER: PCN-03780-00-0A  
 4. SPEC PLS. REFER TO SPEC-92207-XXXX-XXX  
 5. PACKAGE PLS. REFER TO 92208-034XX-XXX-PCK  
 6. PART NUMBER  
 7. THE PART DIMENSIONS ABOUT CONNECT CABLE AND PLUG-IN MUST FOLLOW THE USCAR:064-U-012-2-Z02 / 064-U-008-2-Z02 / 064-U-014-2-Z01

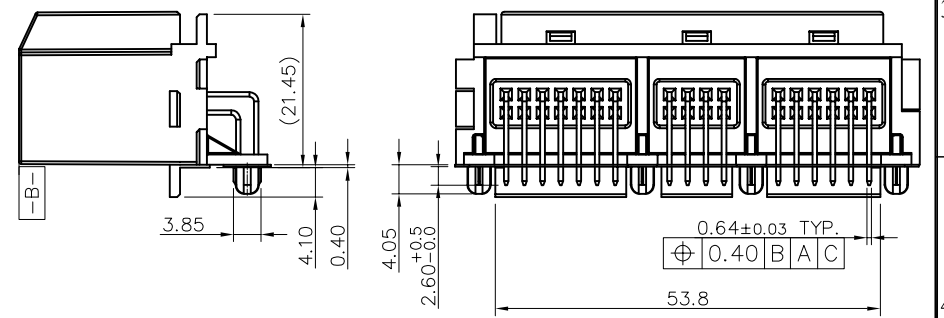

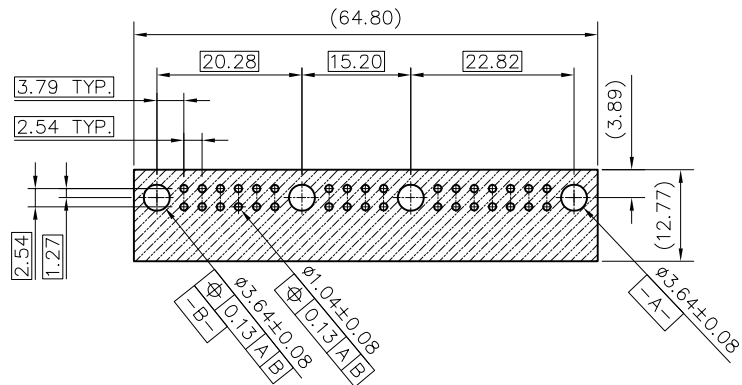

92208-034 X X -XXX  
 NO OF CKT. XXX:  
 034: 34PIN 001: BLACK  
 PACKING: PLATING:  
 2: TRAY N: LEAD FREE  
 (MATT TIN)  
 8. DATE CODE 編碼原則 92207-020XX-XXX  
 0 A 08 T 廠別代碼  
 年分代碼 0=2010年 T=TW-台灣  
 月份代碼 A(1月),B(2月)... D=DC-東莞  
 日期代碼 8=08號 E=KS-昆山長江廠  
 廠別代碼 K=KS-昆山青陽廠  
 重工品代碼 "&"、"\_"、非重工品代碼為空白 G=CC-重慶



QUALITY SYMBOLS	DRAWN BY	DATE	<b>ACES</b> ELECTRONICS
MAJOR Ⓜ QUARTERLY ⓧ	Lin, Liang Ju	19/01/08	
CRITICAL Ⓢ	CHECKED BY	DATE	2.54mm WTB Wafer Conn. CONN. T/H D/R R/A Type
GENERAL TOLERANCES (UNLESS SPECIFIED)	Lee, Kuang En	19/01/08	
X. ±0.5	APPROVED BY	DATE	SIZE
.X ±0.25	Lee, Kuang En	19/01/08	A4
.XX ±0.13	UNITS		DWG NO.
.XXX ±****	mm		92208-034XX-XXX
ANGLES ±2°	SCALE	SHEET NO.	PART NO.
	2:1	2 OF 1	SEE NOTES



 RESTRICTED AREA  
 NO COMPONENTS ALLOWED  
RECOMMEND PCB LAYOUT

QUALITY SYMBOLS MAJOR  QUARTERLY  CRITICAL  GENERAL TOLERANCES (UNLESS SPECIFIED) X. ±0.5 .X ±0.25 .XX ±0.13 .XXX ±**** ANGLES ±2°	DRAWN BY Lin, Liang Ju	DATE 19/01/08			
	CHECKED BY Lee, Kuang En	DATE 19/01/08			TITLE 2.54mm WTB Wafer Conn. CONN. T/H D/R R/A Type
APPROVED BY Lee, Kuang En	DATE 19/01/08	UNITS mm		SIZE A4	DWG NO. 92208-034XX-XXX
	SCALE 2 : 1	SHEET NO. 2 OF 2	REV C	PART NO. SEE NOTES	